

## STERILIZATION & CLEANING PROCEDURES

# Robb Leg Positioner

Product No: 2630-11

Made of aluminum and stainless steel.

Can be pre-vacuum steam sterilized **wrapped or unwrapped**, with the footpiece detached from the base.

Includes an aluminum footpiece or an optional carbon fiber footpiece.

*Please use the following guidelines when sterilizing this product:*

<b>Sterilizer Type:</b>	<b>Pre-vacuum Steam Sterilizer</b>
Minimum Temperature:	132 degrees C / 270 degrees F
<b>Minimum Cycle Time:</b>	<b>4 minutes</b>
Minimum Dry Time:	30 minutes

### AUTOMATED CLEANING CYCLE

Validated Parameters for Stainless Steel, Aluminum, Delrin, Silicone and CF PEEK

- 1) Follow your facility's policy and disassemble as applicable. The base plate screws are assembled with LocTite and may be hard to remove. Removal will require three different sizes of wrenches; 3/32, 5/32 and 1/8 Allen Wrench. Please keep in mind when re-assembling this unit, the base plate screws are stainless steel and the base unit is aluminum, which will require caution when re-attaching.

The boot is not designed to be disassembled.

The locking bar can be removed by rotating and pulling it towards you until it reaches an internal groove and disengages.

- 2) Load the instruments in the washer so that the design features are exposed to cleaning.
- 3) Devices capable of holding liquid should be load such that the design feature can drain.
- 4) Ensure washer is filled with dunnage to simulate a full load.

*The following guidelines are recommended for cleaning. Other automatic cleaning solutions that can be used are Neodisher®, Mediclean Forte®, Thermostept®.*

<b>Phase</b>	<b>Time (MM:SS)</b>	<b>Temp (C°)</b>	<b>Detergent</b>
Prewash	2:00	Cold Water	
Wash	3:00	60+/-5°C	Enzol®
Rinse	0:15	60+/-5°C	
Final Rinse	1:00	80+/-5°C-DIW	
Dry Time	6:00	≥ 80°C	

### MANUAL CLEANING

Validated parameters for Stainless Steel, Aluminum, Delrin, Silicone and CF PEEK

- 1) Follow your facility's policy and disassemble as applicable. The screws are assembled with LocTite and may be hard to remove. Removal will require three different sizes of wrenches; 3/32,

5/32 and 1/8 Allen Wrench. Please keep in mind when re-assembling this unit, the screws are stainless steel and the base unit is aluminum, which will require caution when re-attaching.

The locking bar can be removed by rotating and pulling it towards you until it reaches an internal groove and disengages.

- 2) Rinse the instruments under running, cold water to remove gross soil. Actuate the articles during rinsing.
- 3) Prepare the cleaning solution Enzol® by using 22.2 mL detergent + 3,785 mL tap water.
- 4) Immerse the instruments in prepared Enzol® solution for one (1) minute.
- 5) Prepare Valsure® Neutral solution by using 5.5 mL + 3,785 mL tap water and place in ultrasonic bath.
- 6) Transfer the instruments to the ultrasonic bath and allow to sonicate while fully immersed for 15 minutes.
- 7) After sonication, while the instruments are in Valsure® Neutral solution, scrub the articles thoroughly using a soft-bristled brush (Spectrum M-16 or equivalent). Give the particular attention any hinges, crevices, and hard to reach areas. Actuate instruments while brushing.
- 8) Rinse the instruments for one (1) minute under running de-ionized water (DI) until all traces of the cleaning solution is removed. Give particular attention to any cannulations, blind holds, hinges, joints, and other hard to reach areas. Actuate instruments during rinsing.
- 9) Flush any cannulations, blind spots, joints, or other hard to reach areas with 50 mL DI water. Perform the flush two (2) more times for a total of three (3) times.
- 10) Dry the instruments with a clean, lint free cloth.
- 11) Visually inspect each instrument for soil. If any remains, repeat the procedure.
- 12) Following washing, verify there are no traces of detergent left on the boot. This could cause staining to the boot during the sterilization process. The boot is not meant to be dismantled prior to cleaning.

**To remove the locking handle, rotate and pull bar toward you until it reaches the groove and disengages.**

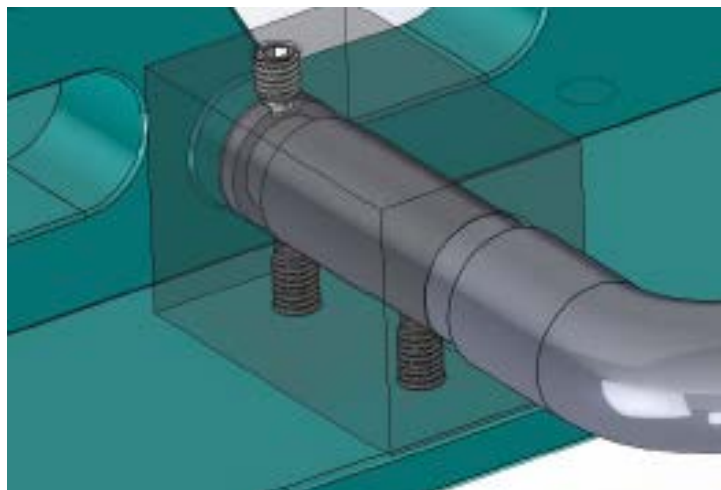

— continued on next page —

FREE TRIAL ON MOST INSTRUMENTS



103 Estus Drive, Savannah, GA 31404  
www.innomed.net info@innomed.net

912.236.0000 Phone  
912.236.7766 Fax

© 2021 Innomed, Inc.

Innomed-Europe Tel. +41 41 740 67 74  
Fax +41 41 740 67 71

# INNOMED

1.800.548.2362

## **Carbon Fiber Footpiece**

Caution: As with any fragile fiberglass material, this footpiece can be damaged if not handled properly and with great care. Do not throw/toss it or let this footpiece rub against other items. Damage could occur if boot comes in contact with harder materials such as metal. As with all materials, special care should be used to prevent damage.

Fraying/Damage — in most cases, fraying is a result of foot piece having contact with instruments made of metal or similar material. Care should be used during cleaning and storage to safeguard against damage. Foot piece is constructed of fiberglass that is very strong and durable but like any material can be damaged if not handled properly.

Take care during transporting, cleaning and storage.

Seeing discoloration or residue on and around the edges of the footpiece:

Discoloration — in most cases is a result of detergent buildup or another type of matter. Clean boot thoroughly with Isopropyl Alcohol and if discoloration still exists, send the product back for evaluation. Staining does not change the fit, form, or function of the boot.