

Cannestra Hip Length Gauge

Designed by Vince Cannestra, MD

Helps determine leg length and hip offset in total hip arthroplasty, including minimally invasive techniques

Set consists of one Ruler, one Pin Inserter/Extractor Handle, one 100 mm Pin, one 130 mm Pin, and a case.

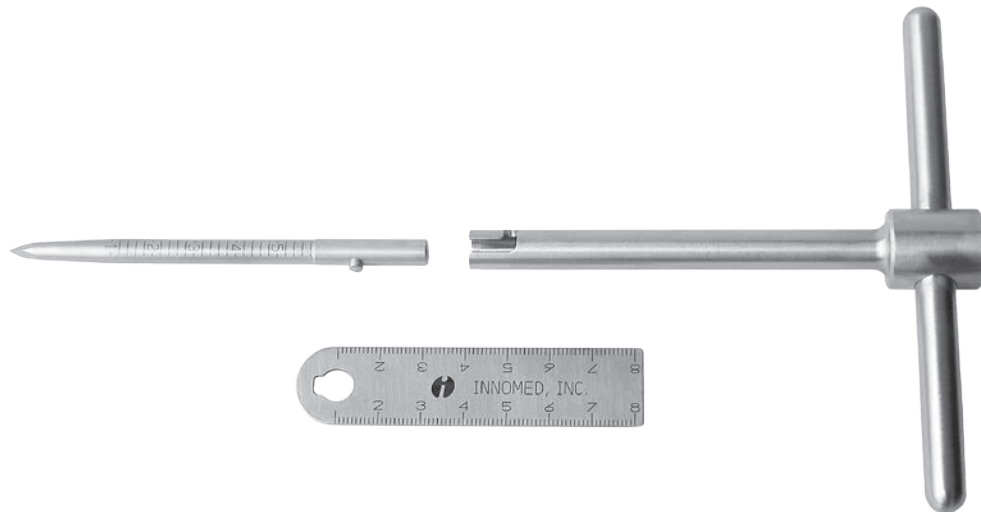

PRODUCT NO'S:
1327-00 [Set]
Set Includes / Replacement Parts:
1327-01 [Pin – 100mm]
1327-02 [T-Handle] Dimensions: 8" x 5" (20,3 cm x 12,7 cm)
1327-03 [Ruler]
1327-04 [Pin – 130mm]
1025 [Sterilizable Case]



— over —

ISO 9001:2008 • ISO 13485:2003

FREE TRIAL ON MOST INSTRUMENTS

Scan to
Launch Our
Website



103 Estus Drive, Savannah, GA 31404
www.innomed.net info@innomed.net

912.236.0000 Phone
912.236.7766 Fax

Innomed-Europe Tel. +41 41 740 67 74
Fax +41 41 740 67 71



1.800.548.2362

Cannestra Hip Length Gauge

Designed by Vince Cannestra, MD

Helps determine leg length and hip offset in total hip arthroplasty, including minimally invasive techniques

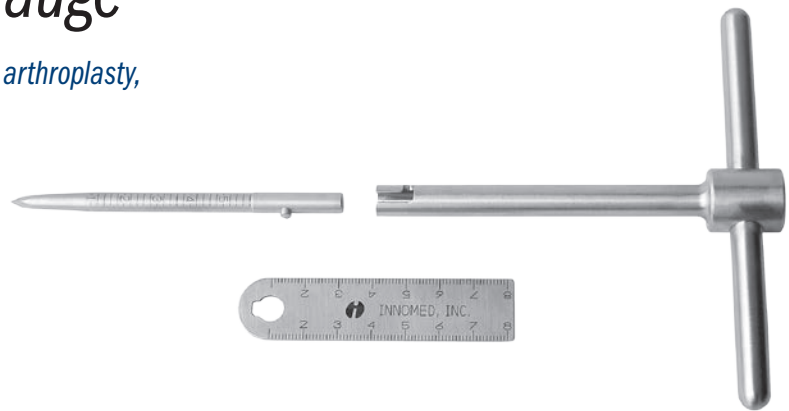

After incising the hip capsule prior to dislocating the hip, the graduated bone pin is inserted just proximal to the acetabular roof from the lateral direction ("A" in Figs. 1 & 2).

The legs are aligned together so that the patellae and heels are collinear and so that the position can be duplicated later in the course of the procedure.

The ruler is inserted over the bone pin until it lays flush on top of or level with the vastus tubercle of the greater trochanter. (Figs. 1 & 2)

The initial hip offset is noted from the markings on the bone pin at the point it intersects with the ruler (Fig. 3). A reference point or mark is made along the ruler as it lays on the greater

trochanter to indicate initial leg length. A stitch or electrocautery mark may suffice to tag the soft tissue at this reference point, i.e. 5 cm. along the ruler (Fig. 3).

The ruler is removed, the hip dislocated and the total hip arthroplasty performed.

Once the trial components or prosthetic implants have been inserted, the legs are realigned as before and the ruler is again inserted over the bone pin. Any change in the level of the ruler along the bone pin will indicate the amount of change in the hip offset (Fig. 4). The closer the ruler is towards the end of the bone pin, the greater the hip offset. Any change in position of the reference mark from its original location along the ruler will determine the relative lengthening or shortening of the leg (Fig. 4).

